

Trigger IO Manual

C-Cam Technologies

a division of

Vector International

1 Introduction

This manual describes the trigger input-output feature of cameras produced by C-Cam Technologies. It covers the BC family, the FC family and the VC OEM models.

Initially a 3-pin connector, the trigger circuit was modified to 5-pins with the advent of the BCv-1300 camera. This then provides for fully isolated input and output and also the facility for a 24 volt trigger pulse.

The hardware trigger facility allows the system designer to synchronize operation of the camera with external events.

For example: An input pulse can be used to start image acquisition, and an output pulse to control illumination.

The description includes details of the physical and electrical characteristics, and how to program the different modes of operation via CCAPI, the application programmer's interface

NOTE: The FCi4-14000 has some additional trigger features that are not described here. Please refer to the FCi4-14000 User's Manual for details.

2 Revision History

Revision	Date-Author	Changes made
V1.3	25/6/2008 pmb	Add description of Trigger Delay
		Trigger I/O circuit description improved
V1.4	17/2/2009 jb	Added edge trigger setting
V1.5	05/01/2011 pmb	Added VC circuit
V1.6	12/01/2011	Added 5-pin trigger circuit (BCv-1300)

3 Timing characteristics

The trigger input has to be activated or deactivated for at least 10 micro seconds to let the photo detector respond properly.

The same goes for the trigger output, it has to be activated or deactivated for at least 10 micro seconds to have a proper pulse at the output pin. (See software paragraph further on in this document)

There is also a latency of several microseconds on the trigger input caused by the transmission time through the opto-isolators and the processing of the internal logic. This must be added to any programmed Trigger Delay (see below).

Please refer to the specific camera User's Manual for details of this delay.

4 Software

The references made to the functions in this document are all from the CCAPI.DLL library. Refer to the Programmers Reference Manual for more information on these functions.

4.1 Using the camera trigger input

The trigger input can be used to start a single frame capture or to start a continuous capture stream. The way you use the trigger input can be defined by each of the **CC_Capture** calls (**CC_CaptureSingle**, **CC_CaptureContinuous**, ...). You have to set the **CC_TRIGGER_MODE** parameter in the argument list of these functions according to the following table :

CC_TRIGGER_MODE	Function
CC_NO_TRIGGER	The trigger input is disabled and the camera can only be started by a software command.
CC_CAMERA_TRIGGER_SINGLE	The camera will be armed with one of the CC_Capture functions. A single frame capture will be started upon an active trigger input. If the camera is used in continuous mode, one active trigger is needed for each frame.
CC_CAMERA_TRIGGER_CONTINUOUS	This setting can only be used with the CC_CaptureContinuous function. The camera will be armed with this function. A continuous stream capture will be started upon an active trigger input.

Note that if the trigger input is held active, the camera will always trigger immediately upon a new capture start command. This can be overridden by setting the bit **CC_CAMERA_TRIGGER_EDGE** in the trigger settings (see below)

The time between the trigger input going active and the start of integration can be determined using the Trigger Delay parameter in the **CC_SetParameter** function. (Default value = zero)

This parameter is only applicable to the hardware trigger input and does not have any effect for software 'Capture' commands.

Parameter	Description
CC_PAR_CAMERA_TRIGGER_DELAY	Determines the trigger delay in micro seconds

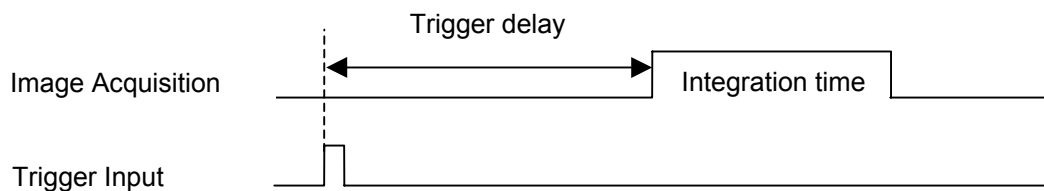

4.2 Using the camera flash output

The trigger output is always enabled. You can set the trigger output pulse delay and width for use with an external flash light for example (See also trigger settings). At startup, these values are zero and no pulse will be generated.

You can change these values with the following parameters in the **CC_SetParameter** function :

Parameter	Description
CC_PAR_CAMERA_FLASH_DELAY	Determines the pulse delay in micro seconds
CC_PAR_CAMERA_FLASH_WIDTH	Determines the pulse width in micro seconds

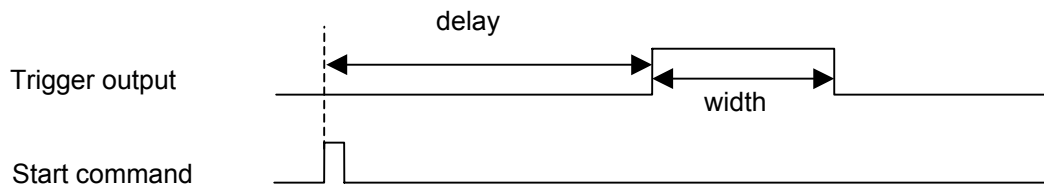

Note that the minimum pulse width should be > 10 micro seconds due to the switching characteristics of the optocoupler.

4.3 Trigger settings

The trigger input and output capabilities of the camera can be set using the **CC_PAR_CAMERA_TRIGGER_SETTINGS** parameter. Although **CC_PAR_CAMERA_TRIGGER_SETTINGS** is an enumeration, a combination of different settings may be OR'ed together. When this parameter is set, all previous settings to this parameter are lost.

CC_CAMERA_TRIGGER_SETTINGS	Function
CC_CAMERA_TRIGGER_INVERT_TRIGGER_IN	Makes the trigger input active high, the default is active low.
CC_CAMERA_TRIGGER_INVERT_TRIGGER_OUT	Makes the trigger output active high, the default is active low.
CC_CAMERA_TRIGGER_EDGE	Makes the trigger react to an edge rather than to the level of the input signal
CC_CAMERA_TRIGGER_ARM	Use this setting if the camera should be armed without using one of the capture functions.
CC_CAMERA_TRIGGER_ARMED_OUTPUT	To use the trigger output signal as an arm ready signal. The default is that the trigger output is used as a flash output (see flash settings).

5 BC & FC Cameras - Trigger I/O connector

5.1 Pin Description

Camera connector type: Binder 712 series, 3-pole male PCB

Pin	Description	Wire Color
1	Trigger Input	White
2	Trigger Common	Brown
3	Trigger Output	Black

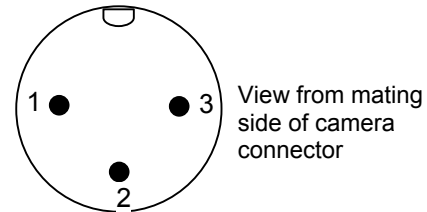

Mating cable connector: Binder 712 series female 3-pole.

5.2 Electrical Schematic

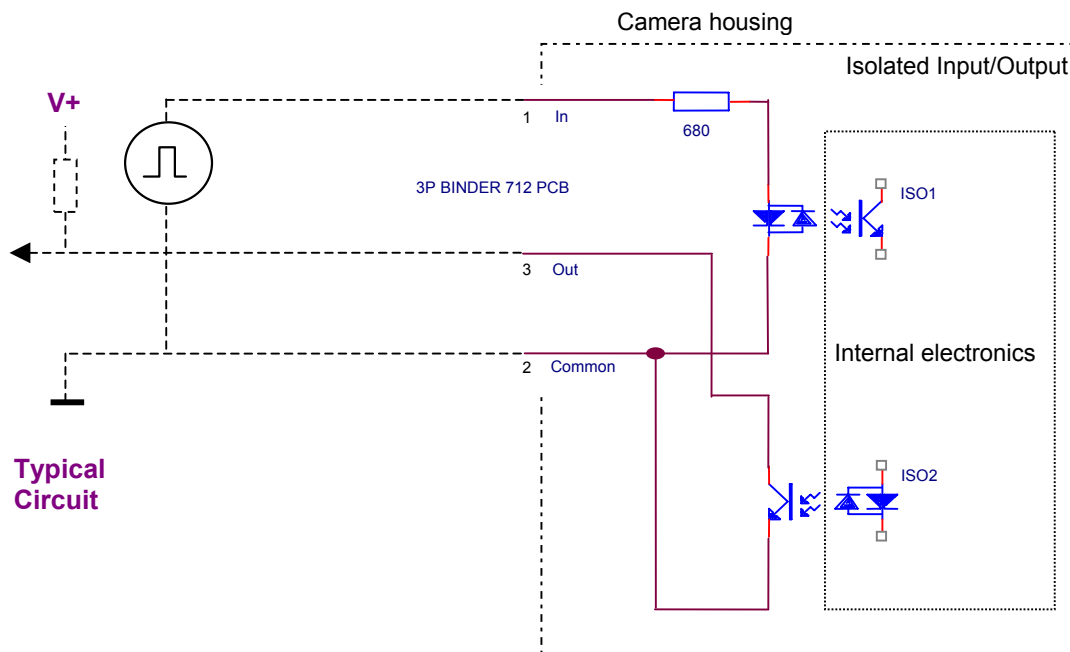

NOTE: The Trigger Common (Pin2) is not connected to the camera body.

5.3 Recommended Operating Conditions

Characteristic	Min	Typ	Max
Supply voltage (1)	-	5V	48V
Diode current	-	5mA	20mA
Collector current	-	1mA	10mA

(1) The internal 680 ohm resistor is for a 5V supply, for higher supply voltages use an extra external resistor in series.

6 VC Cameras – Trigger I/O Connector

6.1 – Pin Description

Camera connector type: PHOENIX MCV 1,5/4-G-3,81 4-pole male PCB

Cable connector type: PHOENIX MC 1,5/4-ST-3,81 (Screw terminals)

Pin	Description	Wire Color
1	Trigger Input ⁽¹⁾	Red
2	Trigger Input	Blue
3	Trigger Output +	Green
4	Trigger Output -	Yellow

- (1) <0.8v = Trigger input “inactive”
3v to 48v = Trigger input “active”



1 2 3 4
Trigger I/O
Connector

6.2 Electrical Schematic

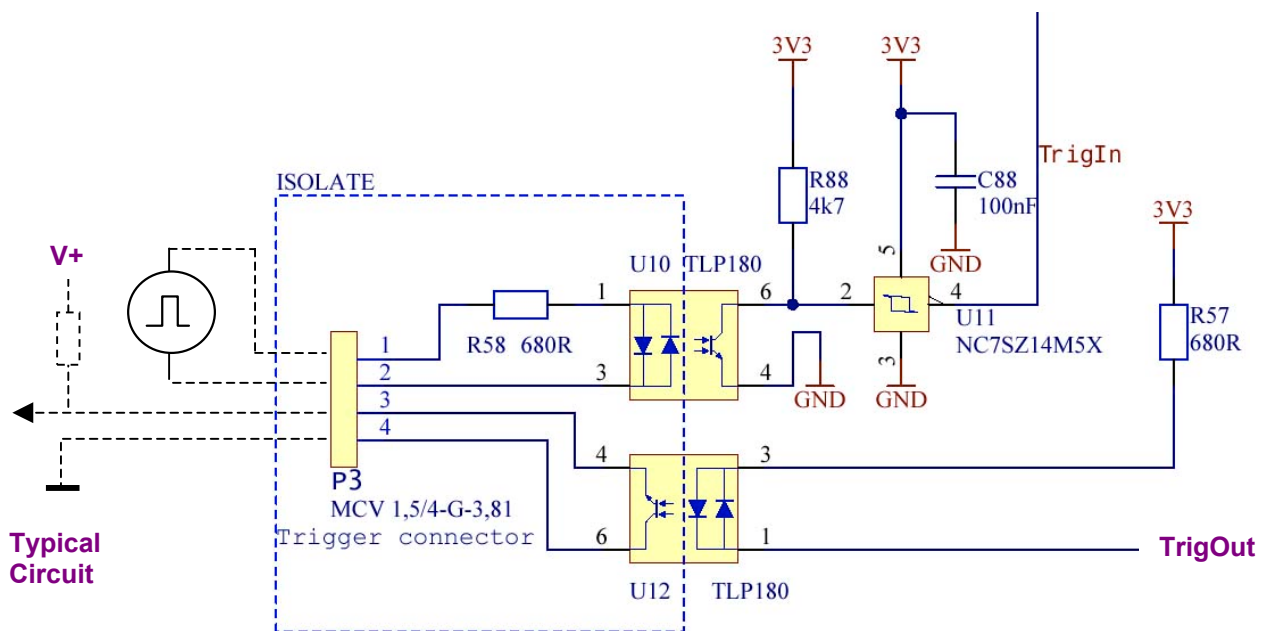

7 5-pin Trigger I/O Connector

7.1 – Pin Description

Camera connector type: Binder 712 series, 5-pole male PCB

Pin	Description	Wire Color
1	Trigger Input (5v)	
2	Trigger Input	
3	Trigger Input (24v)	
4	Trigger Output +	
5	Trigger Output -	

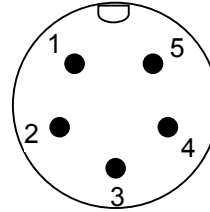

View from mating side of (male) camera connector

Mating cable connector: Binder 712 series female 5-pole.

7.2 Electrical Schematic

